

Pizza counters 2-door and 6-drawer Refrigerated Counter with Show Case

ITEM # _____

MODEL # _____

NAME # _____

SIS # _____

AIA # _____

725188 (RCSH2D6W)

 2-door and 6-drawer
 Refrigerated Counter with
 show case, 0+10°C, AISI 304

Short Form Specification

Item No. _____

Refrigerated counter with front and side panels, doors and drawers in 304 AISI stainless steel. Fitted with a granite worktop. Refrigerated section with 2 doors. Ambient section with 6 drawers suited for use with 1/1GN (not included). Built-in refrigeration unit. Ventilated/Static. Refrigerant R290. High-density expanded polyurethane foam, 90 mm in thickness, with cyclopentane injection. Digital control panel. Completely automatic defrosting and automatic evaporation of defrost water obtained by hot gas. Temperature range: -2+10°C. Suitable to operate in ambient temperatures up to +43°C. CFC and HCFC free. Feet in 304 AISI stainless steel, adjustable in height.

Show case in 304 AISI stainless steel with protective glass panels, sides and upper support shelf. It is designed for use with 1/4GN and 1/2GN containers (not included). Built-in refrigeration unit. Refrigerant R290. Thermostatic temperature control. Temperature range: 0+10°C. IP20 protection.

Main Features

- Showcase and counter equipped with temperature setting, probe monitoring, HACCP alarms, service alarms and parameters customization as standard; remote HACCP monitoring available through an accessory kit.
- Connectivity ready for real time access to connected appliances from remote and data monitoring (requires optional accessory).
- Complies with main international certification bodies and is CE marked.
- Granite worktop for easy and fast dough spreading. 165mm high upstand to prevent foodstuff from accidentally falling from the sides and back during the preparation phase.
- Designed for use with the specific sets of stainless steel 1/4 and 1/2 GN containers (without lids) which are available as accessories.
- 1/2 or 1/3 drawers kits can be fitted on site as an alternative to the doors.
- Showcase suitable to accommodate ¼ and ½ GN trays available as accessories.
- Neutral set of drawers on the right side allows dough storage both in GN 1/1 or 60x40cm trays.
- Refrigerated compartments can accommodate GN 1/1 grids or trays.
- Tropicalized unit.

APPROVAL: _____

Construction

- Counter to feature built-in cooling unit with ventilated cavity and hidden evaporator foamed in the backside designed to work at +10°C even at 43°C ambient temperature.
- Showcase with built-in, independent cooling unit with hidden evaporator designed to keep the food on covered trays between 0 °C and +10 °C at 43°C ambient temperature.
- Developed and produced in ISO 9001 and ISO 14001 certified factory.
- Rounded internal corners. Drain and magnetic gaskets are removable without the use of tools and the condenser filter can be accessed quickly for ease of cleaning.
- Showcase constructed in A304 stainless steel with rounded corners and tempered glass sides, backpanel and upper shelf.
- Showcase provided with power supply cable exit on left or back sides to suit all type of installations.
- Mounted on 150 mm adjustable feet.

Sustainability



- CFC and HCFC free, highly ecological refrigerant type: R290 (ecological gas in foam: cyclopentane). Hydrocarbon refrigerant gas R290 for the lowest environmental impact (GWP=3), to reduce green house and ozone depletion effects.
- Provided with its own integral, highly efficient refrigeration unit with low noise emission and reduced energy consumption. Temperature thermostatically controlled.
- Counter constructed in A304 stainless steel with aluminum internal backpanel for low energy consumption, fast temperature recovery and optimal temperature uniformity.
- Automatic evaporation of the defrosting water by hot gas on the top for energy saving.

Included Accessories

- 2 of 1/1GN grey rilsan grid PNC 881435

Optional Accessories

- 1/1GN grey rilsan grid PNC 881435
- GN containers for refrigerated 1780 mm show case - n. 4x1/4 + n. 2x1/2 h. 150 mm PNC 921850
- Polythene food container 400x600 mm PNC 921854

Front

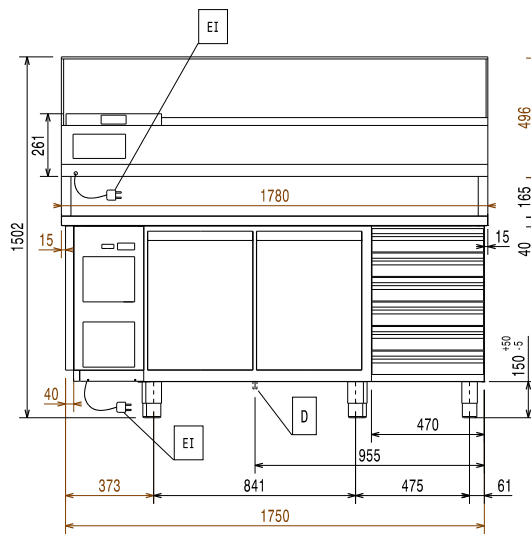

Side

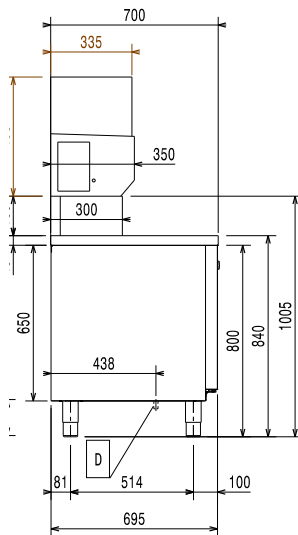

EI = Electrical inlet (power)

Top

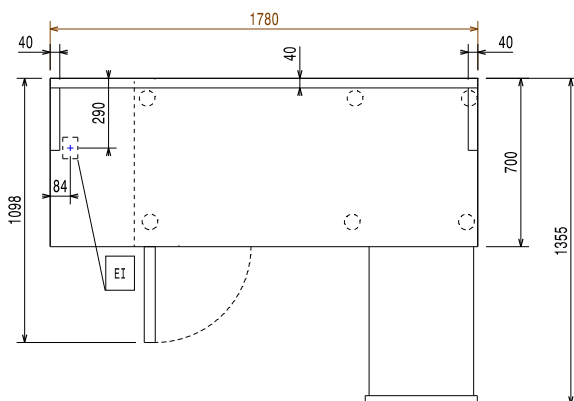

Electric

Supply voltage:	220-240/1/50 V/ph/Hz
Electrical power max.:	0,42 kW
Defrost power:	0,2 kW
Current consumption:	3,0 Amps
Plug type:	CE-SCHUKO

Key Information:

Gross capacity counter:	
725188 (RCSH2D6W)	290 lt
Net volume counter:	164 lt
External dimensions, Width:	1780 mm
External dimensions, Depth:	700 mm
External dimensions, Depth with Doors Open:	1098 mm
External dimensions, Height:	1502 mm
Net weight:	331 kg

Refrigeration Data

Compressor power:	1/3 hp
Second Unit - Compressor power:	1/3 hp
Refrigeration power:	352 W
Second Unit - refrigeration power:	314 W
Refrigerant weight:	50 g
Second Unit - refrigerant weight:	52 g
Refrigeration power at evaporation temperature:	-10 °C

Product Information (EU Regulation 2015/1094)

Energy class counter:	A
Yearly and daily energy consumption counter:	400kWh/year - 1kW/24h

ISO Certificates

ISO Standards:	ISO 9001; ISO 14001; ISO 45001; ISO 50001
----------------	---

Sustainability

Refrigerant type:	R290
Climatic class:	5